

SOLUTION

HORIZONTAL POST STYLE

HFA260P (PA260MPC) • HFA360P (PA360MPC) • HFA460P (PA460MPC)
HFA560P (PA22MPC) • HFA700CII • HFA1000CII



The Vision of Precision



HIGH PRODUCTION SAWING for ALL MATERIALS

HFA260P (PA260MPC) • HFA360P (PA360MPC)
HFA460 (PA460MPC) • HFA560P (PA22MPC)

STANDARD FEATURES HFA260P (PA260MPC) • HFA360P (PA360MPC) HFA460 (PA460MPC) • HFA560P (PA22MPC)

- **SPEED RANGE:** Infinitely variable through a frequency inverter drive and heavy-duty worm gear transmission. The broad speed range allows for optimum cutting of a large spectrum of materials. A read out at the operator's touch screen assures accurate speed setting.
- **BLADE GUIDE:** The hydraulic clamping and combination roller bearing and carbide blade guides reduce heat and blade stress providing longer blade life and accuracies of $\pm .002$ per inch (.051 mm) of cut material. Large anti-vibration rollers help to increase blade life.
- **HYDRAULIC SHUTTLE FEED:** Multi length shuttle indexing up to 999". The shuttle comes to positive stops at both ends of the index, assuring cutoff length accuracy. Repeatability is $\pm .005$ " per index. The shuttle vise jaw floats hydraulically to accommodate crooked stock assuring straight, accurate cuts.
- **HYDRAULIC DOWN FEED:** Feed rate and down pressure can be controlled independently for fast, accurate cutting. Setup is made easy through the color-coded dial allowing the operator to select the optimum setting for the type of material being cut.
- **MPC PROGRAMMABLE CONTROL:** Conveniently located on the operator's control panel, this touch screen control allows the operator to program and store up to 100 jobs. Inputs include Part Length from 0 to 999" (0-25 m) (in inches up to 3 decimal places) and Number of Pieces to be cut.
- **FULL STROKING HYDRAULIC VISE JAWS:** The front vise jaws are split to reduce the remnant. The split vise jaws also help to reduce burrs left on the material and are ideal for bundle cutting, and holding the workpiece.
- **AUTOMATIC CHIP REMOVAL:** The chip auger rotating in the coolant return removes chips quickly and efficiently, freeing the operator to perform more productive operations.
- **VARIABLE VISE PRESSURE:** Hydraulic clamping pressure to the work holding jaws can be adjusted as required to hold solid or thin wall material, allowing the piece to be held securely and without distortion.

OPTIONAL FEATURES HFA260P (PA260MPC) • HFA360P (PA360MPC) HFA460 (PA460MPC) • HFA560P (PA22MPC)

- ROLLER CONVEYORS
- OUT OF SQUARE DETECTOR
- AUTOMATIC MIST LUBE
- HYDRAULIC HOLD DOWNS

Specifications may change without notice at the sole discretion of Amada's Engineering Department.

SAFETY FEATURES

- COVERED CHIP AUGER
- COVER INTERLOCKS
- STALLED OR BROKEN BLADE SENSOR
- LOCKOUT TAGOUT CAPABLE
- TWO HANDED FRONT VISE CLAMP OPERATION
- SAFETY RAILING AROUND SHUTTLE

*Pictures may include some optional equipment.

*Some safety equipment may have been removed or opened to illustrate products clearly and must be in place, and functioning, prior to operation.



VISES



AUTOMATIC CHIP REMOVAL



TOUCH SCREEN CONTROL



FIRST SECTION DEAD ROLLER



STANDARD FEATURES HFA700CII • HFA1000CII

- **BLADE DEVIATION MONITOR:** The NC controller constantly monitors the cutting and blade conditions, including the twist of the saw blade. If these exceed the preset parameters in the automatic blade run-out detector the machine will cease cutting and indicate the reason for stopping.
- **USER-FRIENDLY OPERATOR CONSOLE:** By simplifying required input data, the cutting rate controller (CNC Light) makes achieving maximum cutting rates, accuracies, and longer blade life a constant.
- **MOTION DETECTOR** HFA700CII
- **FULL STROKE VISES** HFA1000CII
- **POWERED CHIP CONVEYOR**
- **WHEEL COVER LIMIT SWITCH** HFA700CII
- **VIBRATION DAMPING ROLLERS**
- **CNC CONTROLLED DOWN FEED**
- **HYDRAULIC BLADE TENSIONING**
- **AUTOMATICALLY POSITIONED GUIDE ARM** HFA700CII
- **BLADE SPEED CONTROLLED BY INVERTER**
- **WORK LIGHT** HFA700CII
- **SUB CONTROL BOX** HFA1000CII
- **OUTBOARD VISE** HFA1000CII
- **FULL STROKE VISES** HFA1000CII
- **AUTO TRIM CUT FUNCTION** HFA1000CII

OPTIONAL FEATURES HFA700CII • HFA1000CII

- **POWER ROLLER TABLE 6.5FT** HFA700CII
- **FREE ROLLER TABLE 6.5FT** HFA700CII
- **POWER ROLLER TABLE 10FT**
- **FREE ROLLER TABLE 10FT**
- **VICE PRESSURE CONTROL VALVE** HFA700CII
- **SUB CONTROL BOX 23FT** HFA700CII
- **SUB CONTROL BOX 65.5FT**
- **VERTICAL CLAMP, MUST BE FACTORY ORDERED** HFA700CII

Specifications may change without notice at the sole discretion of Amada's Engineering Department.

NC FUNCTIONS HFA700CII • HFA1000CII

- **HOURLY METER**
- **BLADE LIFE/HISTORY**
- **NUMBER OF PIECES REQUIRED/CUT**
- **99 CUT-OFF LENGTHS FROM THE SAME BAR**
- **BLADE RUNOUT MONITOR**
- **AUTOMATIC KERF COMPENSATION**

*Pictures may include some optional equipment.

*Some safety equipment may have been removed or opened to illustrate products clearly and must be in place, and functioning, prior to operation.



BLADE DEVIATION MONITOR



POWER CHIP CONVEYOR



AUTO POSITION GUIDE ARM



NC CONTROL PANEL



PRODUCT SPECIFICATIONS & DIMENSIONS

* Voltage Must be Specified When Ordering ** All Other Voltages Require Transformer *** Doesn't include pad height (24 mm)

	HFA260P (PA260MPC)	HFA360P (PA360MPC)	HFA460P (PA460MPC)	HFA560P (PA22MPC)	HFA700CII	HFA1000CII
Rectangular Capacity (WxH)	12" x 10.25"	14" x 14" ()	20" x 18"	22" x 24"	32" x 28" (800 x 700 mm)	15.7" x 3.9"~4.3" x 40" (400 x 100 mm~1100 x 1000 mm)
Round Capacity	10.25"	14"	18"	4.3" - 22" (110 - 550 mm)	11.4" - 28" (290~700 mm)	15.47" - 40" (400 x 1000 mm)
Work Load Capacity	NA	NA	NA	7250 lbs (3288 kg)	17,637 lb (8000 kg)	33,069 lb (15,000 kg)
Single Index Stroke	0.39"-999"	0.39"-999"	0.39"-999"	0.39"-999"	0.39"-999"	0.39"-999"
Material Index Length	10-25000 mm	10-25000 mm	10-25000 mm	10-25000 mm	10 - 9999.9 mm	10 - 9999.9 mm
Blade Speed	65-330 FPM	65-330 FPM	65-330 FPM	78-310 FPM	49-394 FPM	49-394 ft/min, by inverter
Blade Size (L x T x W)	12"11" x 0.42" x 1.25"	14"6" x 0.42" x 1.25"	17"11" x 0.50" x 1.5"	21"8" x 0.63" x 2"	27"3" x 0.063" x 2.625"	36"6" x 0.063" x 3"
Saw Blade Motor	5 HP (3.75 kW)	5 HP (3.75 kW)	10 HP (7.5 kW)	10 HP (7.5 kW)	15 HP (11 kW)	15 HP (11 kW)
Hydraulic Pump Motor	1 HP (.75 kW)	2 HP (1.5 kW)	2 HP (1.5 kW)	3 HP (2.25 kW)	5 HP (3.7 kW)	5 HP (3.7 kW)
Coolant Pump Motor	1/4 HP (0.18 kW)	1/4 HP (0.18 kW)	1/4 HP (0.18 kW)	1/4 HP (0.18 kW)	1/2 HP (0.36 kW)	1/2 HP (0.36 kW)
Voltage Required*	*AC230V± 10%, 3 PH, 60 Hz	*AC230V± 10%, 3 PH, 60 Hz	*AC230V± 10%, 3 PH, 60 Hz	*AC230V± 10%, 3 PH, 60 Hz	**AC220V± 10%, 3 PH, 60 Hz	**AC220V± 10%, 3 PH, 60 Hz
Material Index Remnant Length	NA	NA	NA	NA	1.38" plus length of parts (35 mm plus length of parts)	13" plus length of parts (330 mm plus length of parts)
Head Up Position (W x L x H)	86.9" x 81.3" x 57.7" (2207 x 2065 x 1465 mm)	93" x 83.3" x 68.7" (2363 x 2115 x 1745 mm)	109.2" x 85.4" x 66.4" (2774 x 2170 x 1686 mm)	137.2" x 85.8" x 91" (3485 x 2155 x 2312)	157.4" x 84.0" x 112.9" (3999 x 2133 x 2867 mm)	211.3" x 126.6" x 154.1" (5420 x 3215 x 3924 mm)
Head Down Position (W x L x H)	86.9" x 81.3" x 57.7" (2207 x 2065 x 1465 mm)	86.9" x 81.3" x 68.7" (2207 x 2065 x 1745 mm)	109.2" x 85.4" x 66.4" (2774 x 2170 x 1686 mm)	137.2" x 85.8" x 91" (3485 x 2155 x 2312)	157.4" x 84.0" x 112.9" (3999 x 2133 x 2867 mm)	211.3" x 126.6" x 154.1" (5420 x 3215 x 3924 mm)
Table Height***	26" (663 mm)	26" (663 mm)	28" (708 mm)	30.5" (776 mm)	27.6" (700 mm)	33.5" (850 mm)
Machine Weight	3,860 lbs (1750 kg)	4,850 lbs (2200 kg)	5,357 lbs (2430 kg)	9,920 lbs (4500 kg)	15,435 lb (7000 kg)	31,970 lb (14,500 kg)

HFA260P (PA260MPC)

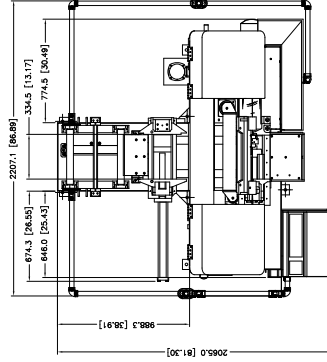

HFA360P (PA360MPC)

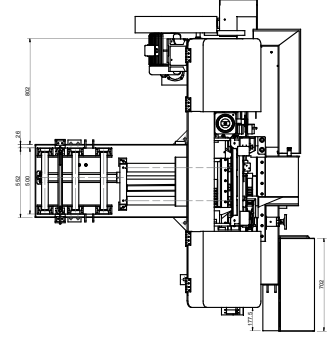

HFA460P (PA460MPC)

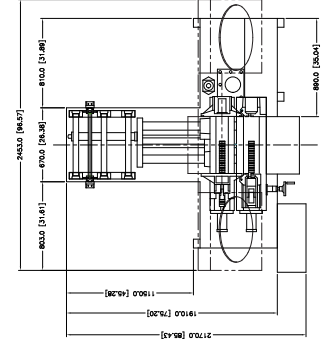

HFA560P (PA22MPC)

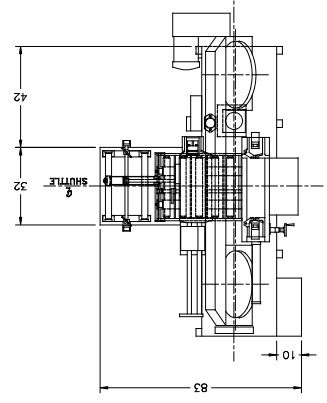

HFA700CII

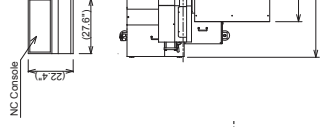

Before using this product, please read the operator's manual carefully and follow all applicable instructions.

- When using our products, safety equipment is required depending on the operational task.
- * Specifications, appearance and equipment are subject to change without notice by reason of improvement.
- * Please use the machine model name as HFA260P, HFA360P, HFA460P, HFA560P, HFA700CII, OR HFA1000CII, when applying for administration applications.
- * For any inquires, please contact local Amada Machinery America, Inc. office.

© AMADA MACHINERY AMERICA, INC. All Rights Reserved.

100 S Puente St · Brea, CA 92821 · Phone: 847.285.4800 · Fax: 847.519.2127

www.amadamca.com



HFA1000CII

