

SOLUTION

HORIZONTAL MITERING

S330/2HV • S330/3HV • SA330WPC • SA1318WPC • SA460WPC
W2543M • WS2543M



STANDARD FEATURES

S330/2HV • S330/3HV

- **SPEED RANGE:** The S330/2HV blade speed is infinitely variable through an Inverter Drive heavy-duty worm gear transmission. Blade speeds are 60-330 feet per minute (18-100 meters per minute). The S330/3HV uses a 4 speed step pulley. Blade speeds are 105, 175, 270 and 375 feet per minute (32, 53, 82, and 114 meters per minute). The broad speed range allows for optimum cutting of a large spectrum of materials.
- **HYDRAULIC DOWN FEED:** Infinitely variable feed rate is hydraulically controlled for fast, accurate cutting. Settings are made at the operator's control station.
- **HYDRAULIC AUTO FRAME RETURN:** The saw frame will automatically raise hydraulically at the end of a saw cut. The saw frame can also be lifted hydraulically with the push button switch.
- **BLADE GUIDES:** Carbide Blade Guides provide reduced vibration, heat and blade stress providing longer blade life.
- **CHIP BRUSH:** Powered from the drive wheel of the saw, the brush changes speed with the blade to assure that chips are being removed from each gullet, improving cutting performance and blade life.
- **WISE JAW:** Hydraulic rack and pawl vise design clamps and holds the work piece securely. The vise is operated by a selector switch located on the operator's control panel.
- **SWIVEL MITER:** The saw frame swivels a full 60 degrees to the rear and 45 degrees to the front for optimum miter cutting capability. Stops are provided at -60 and +45 degrees.
- **OPERATORS CONTROL PANEL:** Operation of the machine is safe and convenient from the swing arm pedestal mounted on the machine base. Control Voltage is 110V.
- **16" (407 MM) DIAMETER CAST IRON BLADE WHEELS**
- **30.5" (775 MM) WORK HEIGHT**
- **BUILT IN COOLANT SYSTEM**
- **ADJUSTABLE GUIDE ARM WITH DOVE TAIL SLIDE**

MOST POPULAR OPTIONAL FEATURES

- **AUTOMATIC MIST LUBE**
- **VARIABLE VISE PRESSURE**
- **FREE STANDING ROLLER TABLE**

*Pictures may include some optional equipment.

*Some safety equipment may have been removed or opened to illustrate products clearly and must be in place, and functioning, prior to operation.



FREQUENCY INVERTER DRIVE



4 SPEED STEP PULLEY BLADE DRIVE



BLADE TENSION



HYDRAULIC VISE JAW RACK



STANDARD FEATURES

W2543M • WS2543M

- **SAW FRAME:** The saw frame is canted at a 6.5 degree angle for faster cutting of structural and other flat materials. The heavy duty saw frame rides up and down a linear way guide system.
- **MITER CUTTING:** The WS2543M model has a saw base that swivels to 45 degrees one direction and 60 degrees the other, for miter cutting. A ½ hp (400 W.) motor turns the machine base and the degree of angle is read out on a LED DISPLAY.
- **SPEED RANGE:** 98-361 FPM (30-110m/min.). Infinitely variable through a frequency inverter system and a heavy duty Worm Gear Transmission. The broad speed range allows for optimum cutting of a large spectrum of materials. An Electric Tachometer assures accurate speed settings.
- **HYDRAULIC DOWN FEED:** Feed rate and down pressure can be controlled for fast, accurate cutting. Setup is made easy through the color-coded dial allowing the operator to select the optimum setting for the type of material being cut.
- **BLADE GUIDES:** A combination of roller bearing and hydraulically actuated carbide blade guides assures the blade is held taut for fast, accurate cuts. The cast iron Movable Guide Arm is positioned through a Hydraulic Cylinder, then is Hydraulically Locked in position.
- **FAST APPROACH:** Work height is manually set allowing the head to raise just enough to clear the work piece, reducing cycle time and allowing for faster cutting performance.
- **CHIP BRUSH:** An Independent Motor drives the blade cleaning Chip Brush to assure complete removal of chips from each gullet of the blade, providing optimum cutting performance and enhanced blade life.
- **WISE JAW:** Full Stroking Vise Jaw and a Vertical Clamp Device assure the work piece is secure and eliminates excessive vibration during the cut providing better blade life and cleaner cuts. Minimum Clamping Capacity is 7.5" (190mm) width.
- **CONTROLS:** An Independent Electric Cabinet and Control Panel allow the operator to position the controls for optimum viewing of the cutting area. A PLC controls all electrical and hydraulic functions.
- **AMADA SST-WS BLADE:** Amada SST Wide Set blade 28'6-1/2" long x 2" wide, 3/4 tooth pitch. This is the standard blade that is included with machine purchase.
- **AUTOMATIC CHIP CONVEYOR:** A motorized conveyor for removal of chips from the machine into a disposal container.
- **HYDRAULIC HOLD DOWN:** Added instead of the single point hold down, for use with bundled or nested material.



SWIVEL BASE



CHIP CONVEYOR



FREE STANDING CONTROL

STANDARD FEATURES

SA330WPC • SA1318WPC • SA460WPC

- **SPEED RANGE:** Infinitely variable through an inverter drive and a heavy-duty worm gear transmission. The broad speed range allows for optimum cutting of a large spectrum of materials. The on screen tachometer assures accurate speed setting.
- **HYDRAULIC DOWN FEED:** Feed rate and down pressure can be controlled for fast, accurate cutting. Setup is made easy through the color-coded dial allowing the operator to select the optimum setting for the type of material being cut.
- **HYDRAULIC SHUTTLE FEED:** Length settings of 0-27.56" (0-700mm) are accomplished with simple programming at the operator's touch screen. The shuttle comes to positive stops at both ends of the index, assuring cutoff length accuracy, reducing material loss. Repeatability is $\pm .005"$ per index.
- **PC PROGRAMMABLE CONTROL:** This touch screen control allows the operator to program and store up to ten jobs. The Blade Speed is displayed on and set using the touch screen, but is not stored in memory. The Automatic Piece Counter stops each job when the pre-set number of cuts has been made.
- **BLADE GUIDES:** The carbide blade guides provide accuracies of $\pm .002$ per inch (.051 mm) of cut material.
- **OUT-OF-STOCK SWITCH:** The machine will shut off automatically when material is no longer present in the rear vise jaws, allowing for truly automatic operation.
- **FULL STROKING HYDRAULIC VISE JAWS:** Hydraulic vices hold the work piece, providing accurate cuts and longer blade life.
- **SHUTTLE VISE:** The shuttle vise jaw floats hydraulically to accommodate crooked stock assuring straight, accurate cuts. Remnant length is 9.5" (241 mm).
- **HYDRAULIC HOLD DOWNS:** Vertically mounted hydraulic clamps located on each vise jaw apply downward pressure to hold multiple bar work or structural shapes.
- **AUTOMATIC CHIP REMOVAL:** The chip auger rotating in the coolant return removes chips quickly and efficiently, freeing the operator to perform more productive operations.

MOST POPULAR OPTIONAL FEATURES

- AUTO MIST LUBE
- EXTENSION DEAD ROLLER TABLE
- VARIABLE VISE PRESSURE CONTROLS
- FIRST SECTION DEAD ROLLER TABLE



CHIP CONVEYOR



VARIABLE VISE PRESSURE



AUTO MIST LUBE



ALIGNMENT GUIDE & BUNDLE CLAMP



HYDRAULIC BLADE TENSION



PC PROGRAMMABLE CONTROL

PRODUCT SPECIFICATIONS & DIMENSIONS

S330/SA330/SA1318/SA460

Capacity	S330/2HV & S330/3HV	SA330WPC	SA1318WPC	SA460WPC
90° Round	13" (330 mm)	13" (330 mm) Min Remnant 9 1/4"	13" (330 mm) Min Remnant 9"	18" (460 mm) Min Remnant 9 1/4"
90° Rectangle	12" H x 18" W (300 x 460 mm)	13" H x 16" W (330 x 406 mm)	13" H x 16" W (330 x 405 mm) 9" H x 18" Max Width (228.5 x 457 mm)	15" H x 24" W (380 x 610 mm) 18" H 23" Max Width (460 x 580 mm)
90° Square	12" (300 mm)	13" (330 mm)	13" (330 mm)	18" (460 mm)
45° Round	13" (330 mm)	11" (280 mm)	11.8" (300 mm)	15" (380 mm)
45° Rectangle	11" x 12" (280 x 330 mm)	11" x 13" (280 x 330 mm)	9.4" H x 13" W (240 x 330 mm)	15" x 15" (380 x 380 mm)
60° Round	9.5" (240 mm)	NA	7" (178 mm)	NA
60° Rectangle	11" x 8" (280 x 203mm)	NA	7.4" H x 11" W (188 x 280 mm)	NA
Blade Speed	<ul style="list-style-type: none"> 60-330 FPM Inverter Drive S330/2HV S330/3HV 	95 - 295 SFPM (29 - 90 m/min)	108 - 340 FPM (33 - 105 m/min)	65 - 330 SFPM (20 - 101 m/min)
Blade Size	13' 6" X 1" X .035"	1" X .035" X 13' 7"	1.25" x .042" x 16' 4"	1-1/2" X .050" X 18' 10"
Blade Drive	3 HP (1.5kW)	5 HP (3.75kW)	5 HP (3.75kW)	5 HP (3.75kW)
Hydraulic Pump	1/2 HP (0.375kW)	1 HP (.75kW)	1 HP (.75kW)	1 HP (.75kW)
Coolant Pump	1/8 HP (0.09kW)	1/8 HP (.1kW)	1/8 HP (.1kW)	1/6 HP (.12kW)
Table Height	30.5" (775 mm)	32.7" (830 mm)	34.5" (876 mm)	36.4" (925 mm)
Machine Weight	1800 lbs (850kg)	3,175 lbs (1440 kg)	4,300 lbs (1950 kg)	6,000 lbs (2721 kg)
Shuttle Length	NA	27.6" (700 mm) 999.999" Max Part Length	27.6" (700 mm) 999.999" Max Part Length	27.6" (700 mm) 999.999" Max Part Length
Max Material Weight for Shuttle Index	NA	4,410 lbs (2000 kg)	5,070 lbs (2300 kg)	8,820 lbs (4000 kg)

S330/2HV, S330/3HV

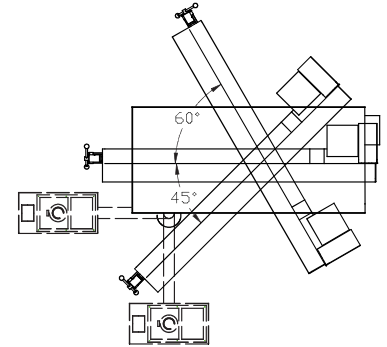
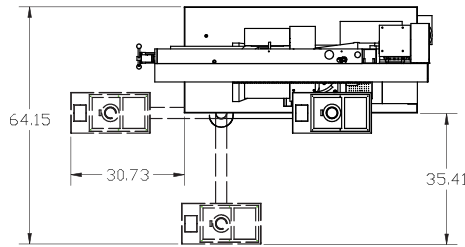

SA330WPC

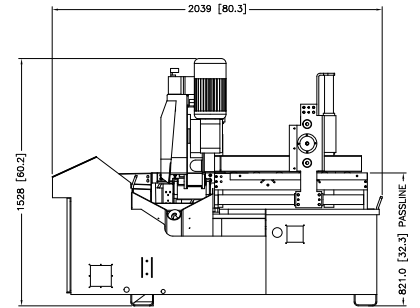
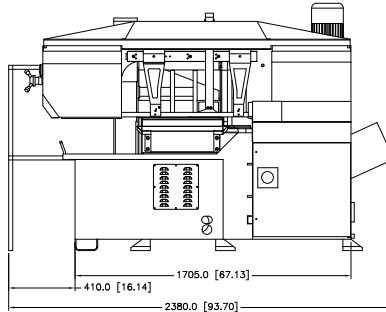

SA1318WPC

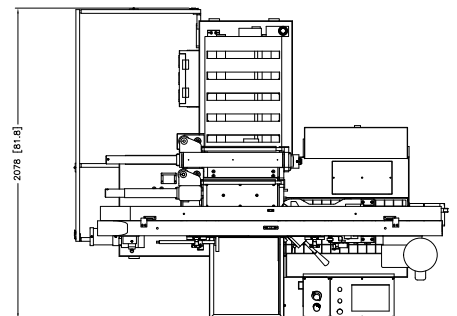
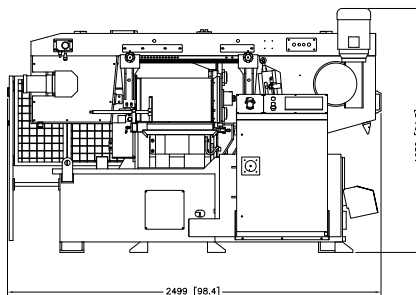

PRODUCT SPECIFICATIONS & DIMENSIONS

W2543M/WS2543M

Capacity	W2543M	WS2543M
90° Round	28" (711 mm)	28" (711 mm)
90° Nominal Rectangular	27" H x 44" W (685.8 x 1117.6 mm)	27" H x 44" W (685.8 x 1117.6 mm)
45° Round	N/A	28" (711mm)
45° Nominal Rectangular	N/A	27" x 25.6" (685.8 x 650 mm)
60° Round	N/A	25.6" (650 mm)
60° Nominal Rectangular	N/A	25.6" H x 15.75" W (650 x 400 mm)
Blade Speed	98-361 FPM (30-110 m/min.)	98-361 FPM (30-110 m/min.)
Blade Size	2" x 28' 6-1/2" x .063" (54 x 8700 x 1.6 mm)	2" x 28' 6-1/2" x .063" (54 x 8700 x 1.6 mm)
Blade Drive	10 H.P. (7.5 kW)	10 H.P. (7.5 kW)
Hydraulic Pump	3 HP (2.2kW)	3 H.P. (2.2 kW)
Coolant Motor	1/4 HP (180W)	1/4 HP, (180W)
Wire Brush Motor	1/12 HP (60W)	1/12 HP (60W)
Roll Motor	NA	1.5 HP (1.1kW)
Table Rotation	NA	1/2 HP, (400W)
Shuttle Length	NA	NA
Shuttle Index	NA	NA
Machine Weight	9,500 lbs (4300 kg)	11,880 lbs (5400 kg)
Machine Floor Space	101" H x 179" W x 89.37" D (2560 H x 4550 W x 2270mm D)	101" H x 179" W x 89.37" D (2560 H x 4550 W x 2270 mm D)
Table Height	32' ~ 33' (810 ~ 850 mm) with Adjustable Pad	32' ~ 33' (830 ~ 850 mm) with Adjustable Pad

SA460WPC

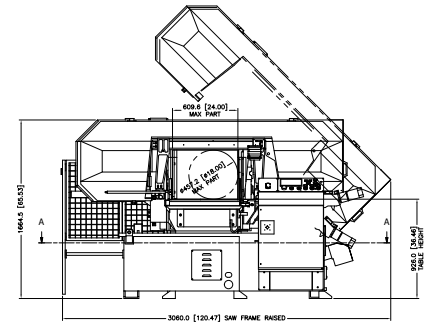
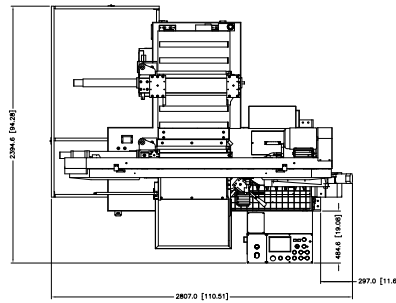

W2543M & WS2543M

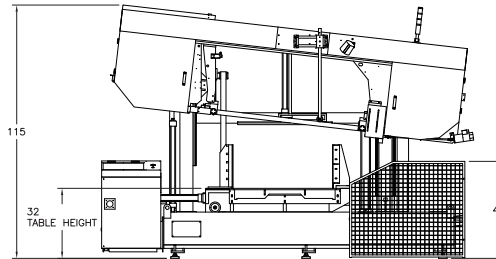

▲ Please note the fencing shown in the W2543M floor plan above is not utilized.

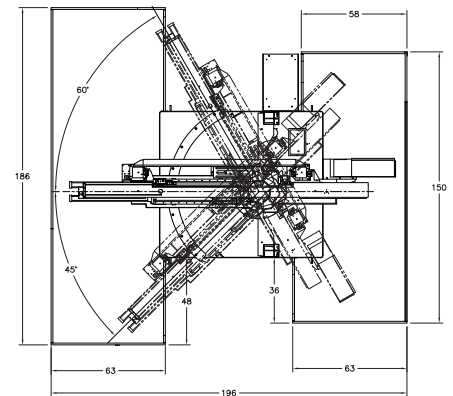

⚠ Before using this product, please read the operator's manual carefully and follow all applicable instructions.

- When using our products, safety equipment is required depending on the operational task.

* Specifications, appearance and equipment are subject to change without notice by reason of improvement.

* Please use the machine model name as S330/2HV, S330/3HV, SA330WPC, SA1318WPC, SA460WPC, W2543M or WS2543M when applying for administration applications.

* For any inquiries, please contact local Amada Machinery America, Inc. office.

© AMADA MACHINERY AMERICA, INC. All Rights Reserved.



100 S Puente St · Brea, CA 92821
Phone: 847.285.4800 · Fax: 847.519.2127

www.amadamca.com

