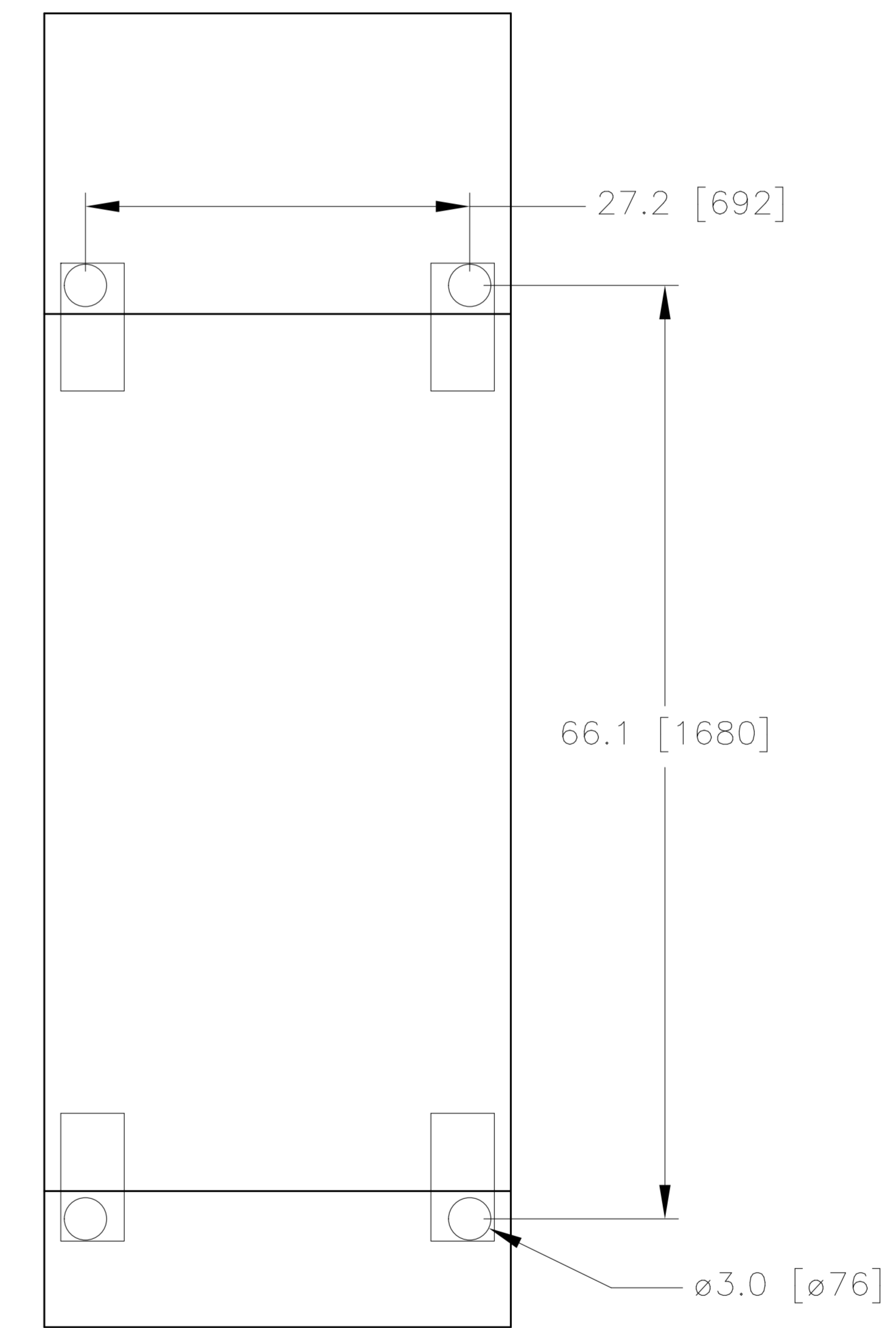
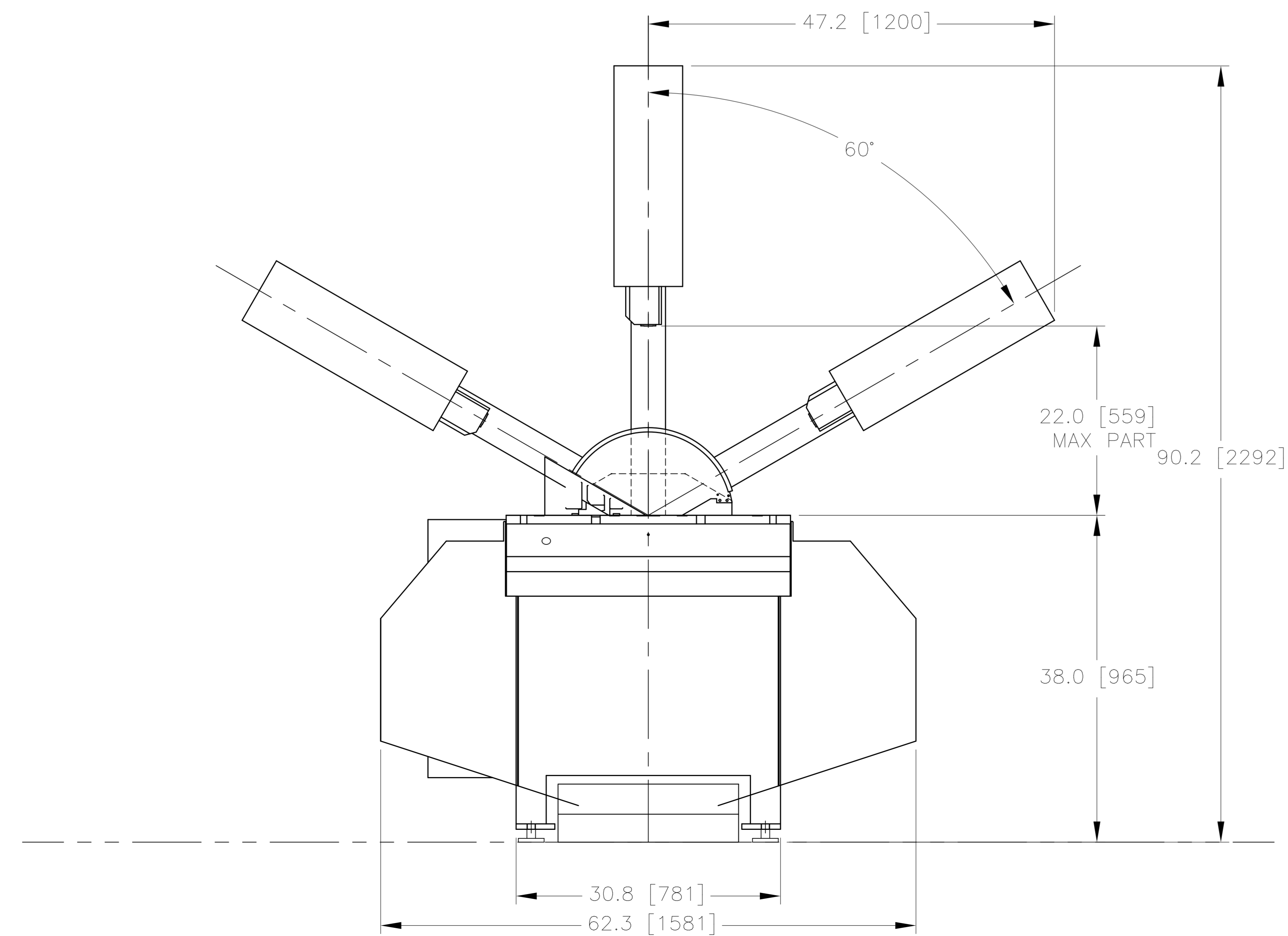

TABLE CROSS-SECTION  
1:4 SCALE



FOOT PAD LOCATION



NOTES:

1. STRAIGHT COLUMN OPTION SHOWN.
2. MEASUREMENT SHOWS REAR MOST POSITION OF BLADE.
3. MEASUREMENT SHOWS MAXIMUM VISE OPENING.

PLOTTED: PLOTDATE

REV	DATE	REMARKS	BY
L			
K			
J			
I			
H			
G			
F			
E	1/22/15	MOVE ELEC PANEL ADD FOOTPRINT	MJB
D	4/16/13	ADDED 22" DIM MAX MATERIAL	MJB
C	5/2/11	TABLE HEIGHT DIM WAS 37"	SJB
B	6/2/10	REV'D SLIDING DOOR REF	SJB
A	1/31/08	ADDED CG AND ANCHOR LOC'S	SJB

FENCING AND AREA GUARDS BY OTHERS  
DIMENSIONS SUBJECT TO CHANGE

TITLE  
8-MarkIII  
Basic Floorplan

COMPANY

CITY, STATE

DATE	SCALE	DRWN BY	CHECKED BY
2/27/07	1:16	RWS	

ALL RIGHTS TO ENGINEERING, DESIGN,  
INVENTIONS AND PATENTS RESERVED  
TO AND PROPERTY OF:

MARVEL MFG. CO.  
OSHKOSH, WI., U.S.A.

CAD NO.

Spec8MIII

PART NO.

Spec8MIII